

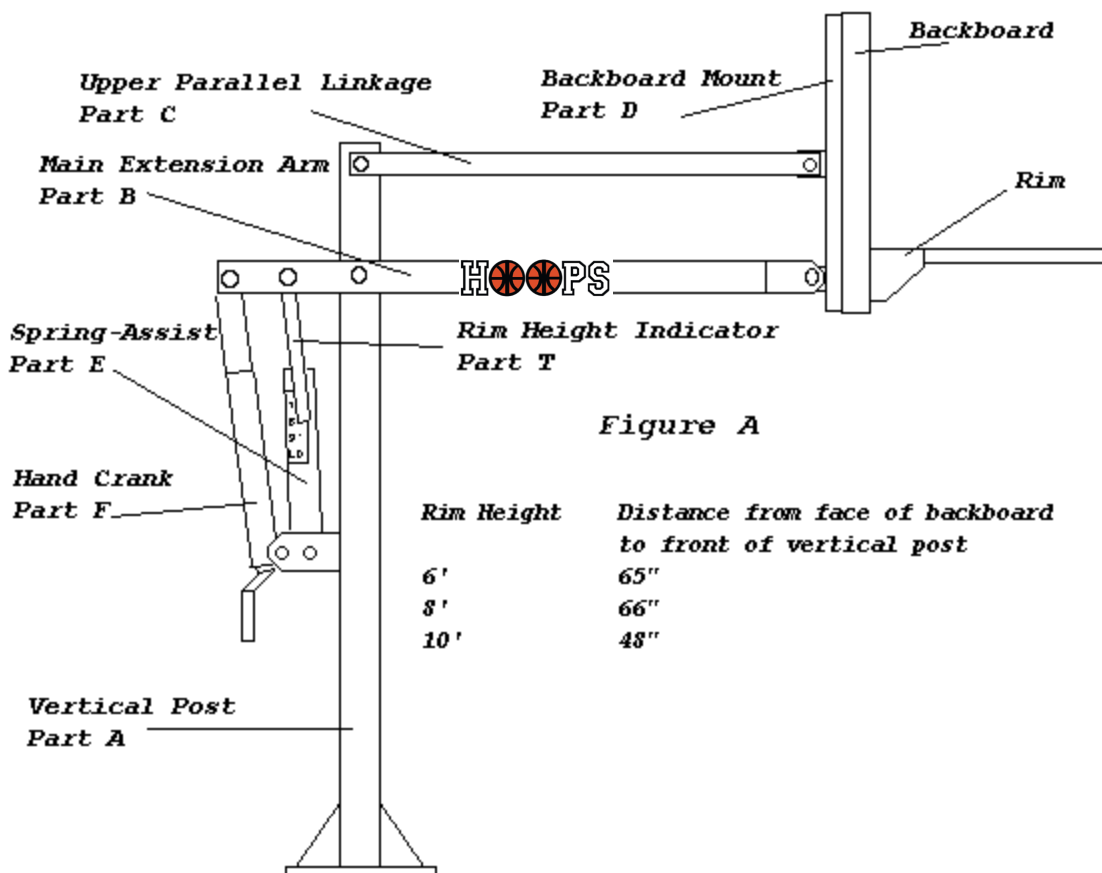

Hoops Pro Dunk® 5x3 Elite Assembly Instructions



Bill of Materials

A(1) Vertical Post	K(4) 5/8" Anchor Bolt
B(1) Main Extension Arm	L(12) 5/8" Hex Nut
C(2) Parallel Linkage	M(1) Anchor Footing Template
D(1) H-Frame Backboard Mount	N(4) Anchor Footing Rebar
E(1) Spring-Assist Cartridge	O(8) 5/16" x 1" Machine Screw
F(1) Crank Adjustment Cylinder	P(8) 5/16" Flat Washer
G(2) 1/2" x 4 1/2" Hex Bolt	Q(8) 5/16" Lock washer
H(5) 1/2" x 10" Hex Bolt	R(8) 5/16" Hex Nut
I(1) 1/2" x 11" Hex Bolt	S(1) Rim Height Sticker
J(8) 1/2" Locknut	T(1) Rim Height Indicator

NOTE: Immediately unpack all components and cross check against bill of materials. Report any shortages to Hoops customer service at 1-866-944-6677.

Hoops Pro Dunk® Elite Premium Assembly Instructions

Instructions

1. Choose the proper location to dig for the concrete footing. Use the distance chart in figure A to help you make your decision. When choosing the exact position to dig, make sure to maximize the amount of playing surface while minimizing possible driveway obstruction.
 2. Dig hole 42" deep and 24" square. Be sure to bell out the bottom 12" of the hole to give added stability to the footing. NOTE: If you live in an area where the frost line is below 42" it is advisable to dig to normal frost line. Do not cheat on the hole size, it is imperative that the hole be a minimum of 42" deep and 24" square!
 3. Assemble the anchor kit as shown in figure B. First thread a 5/8" hex nut (L) 2 ½" of the way on to each J-Bolt (K). Place the threaded end of each J-Bolt through the 4 holes located in the anchor template (M). Then thread a second 5/8" nut on to each J-Bolt until tight against the template, making sure to keep the J-Bolt hooks pointing in toward the center of the template.
 4. For this step you will need: Level; Broomstick; Tape Measure. The 42" x 24" anchor footing will require approximately 1/2 yard of 3000 psi concrete (30-32 60# sacks of premix concrete). More will be needed if you dig a larger hole. Make certain that you have enough concrete to finish the job. Allowing a portion to dry while you purchase more concrete will weaken the footing.
 5. Mix the concrete according to the instructions on the bag. It is better to mix it slightly wet than too dry. Fill the hole full to ground level with as little time between batches as possible. Insert the broomstick in 3 or 4 different places and vibrate up and down to settle the concrete. Submerge the (4) anchor footing rebar pieces (N) into the center of the hole spaced evenly. Next set the anchor bolt assembly into the wet concrete, vibrate it as it goes in to make sure the concrete fills in around the J-Bolt hooks. Make sure the template is pressed firmly against the top of the wet concrete. Use the level to ensure that it is level in all directions. Additionally, the center line of the J-Bolts must be parallel with the edge of the playing surface. (See figure C)
- STOP HERE! Allow footing to cure for seven days before proceeding.
6. Take off the top 5/8" nuts from the J-Bolts, remove the template and discard it.
 7. Thread a second 5/8" nut on to each J-Bolt down against the nut embedded in the concrete.
 8. Place the vertical post (A) down over the footing making sure not to damage the J-Bolt threads. Using the final (4) 5/8" hex nuts, bolt down post finger tight with welded tabs facing away from playing surface.
 9. Level the vertical post by adjusting the 5/8" nuts located underneath the base plate. Then tighten top nuts against the top side of the base plate.
 10. Slide the main arm (B) over the top of the vertical post and attach to the lower pivot tube with a ½" x 10" hex bolt (H) and ½" locknut (J).
 11. Slide the hole located in the rim height indicator (T) (black plastic with hole in one end) over one of the second set of welded tubes in the main arm. Attach the spring-assist cartridge (E) to the second set of attachment holes on both the main arm and the vertical post welded tabs utilizing a ½" x 10" hex bolt (H) and a ½" x 4 ½" hex bolt (G). Tighten each with a ½" locknut (J). The rim height indicator should now hang freely along side the spring-assist cartridge.
 12. Next attach the hand crank adjustment cylinder (F) using a ½" x 10" hex bolt (H) and ½" x 4 ½" hex bolt (G). Tighten each with a ½" locknut (J). Next, remove and discard the cardboard spreader tube from the spring-assist cartridge.
 13. Attach parallel linkages (C) to vertical post with ½" x 10" hex bolt (H) and ½" locknut (J). Attention: It does not matter which end of the parallel link you attach to the vertical post.
Caution: Injury may occur if linkages are allowed to fall off main arm during assembly.
 14. Next, assemble the H-Frame backboard mounting (D) to the backboard as shown in figure D. Use the (8) 5/16" x 1" machine screws (O), (8) 5/16" flat washer (P), (8) 5/16" lock washer (Q), (8) 5/16" hex nuts (R). If your backboard is tempered glass check to make sure all four steel grommets are located at the rim holes, if any are missing check in the box. If grommets are missing and cannot be located, DO NOT proceed with assembly, call Hoops immediately. If your backboard is acrylic you must remove and discard the plastic shipping block from the backboard joint to complete this step. Additionally, if you purchased an acrylic backboard you should have received two rubber gaskets enclosed with the backboard. Place one gasket between the H-Frame backboard mount and the backside of the backboard. You will use the other gasket later during assembly. Rubber gaskets are necessary for acrylic boards only.
 15. Mount the H-Frame/Backboard assembly lower pivot tube first to the main arm using (1) ½" x 11" hex bolt (I) and (1) ½" locknut (J).

Hoops Pro Dunk® Elite Premium Assembly Instructions

Next, attach the upper H-Frame pivot tube to the upper parallel linkages using (1) ½" x 10" hex bolt (H) and (1) ½" locknut (J).

16. Check face of backboard to see if it is level forward and back. If it is out of level, correct it by adjusting the 5/8" nuts located underneath the vertical post base plate.

17. Mount the rim to the H-Frame/Backboard assembly using the hardware supplied in the rim box. If you purchased an acrylic backboard make sure to place the second rubber gasket (included with backboard) between the face of the backboard and the backplate of the rim. Trim gasket if necessary. Use level to make sure rim is level side to side before tightening nuts.

18. After everything is square, make sure all nuts have been tightened. However, do not overtighten, if unit is difficult to crank up and down the main pivot nuts are probably too tight.

19. To apply the rim height sticker (S), first use a tape measure to crank rim up to exactly 10' from the playing surface. Use a pencil to make a mark on the spring-assist outer tube where the rim height indicator stops. Then, peel and apply sticker to outside of spring-assist cartridge lining up the pencil mark with the 10' mark on the sticker. See Figure A for a diagram of a completed height indicator assembly.

Note: It is advisable to wait up to two weeks to allow the anchor footing to fully cure before aggressive play.

Figure B

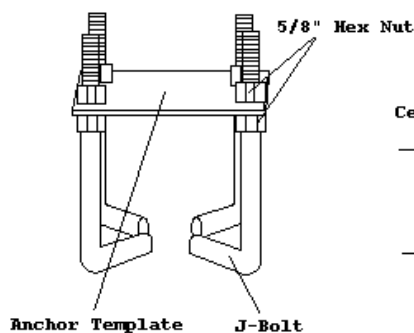

Figure C

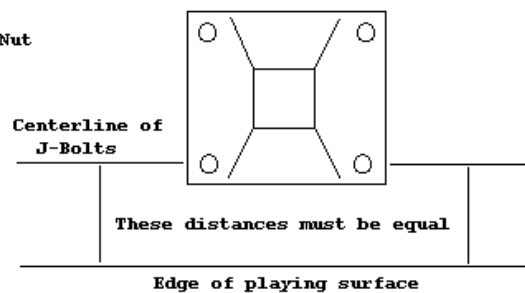

Figure D

