

HOOOPS

Hoops Pro Dunk® Original Assembly Instructions

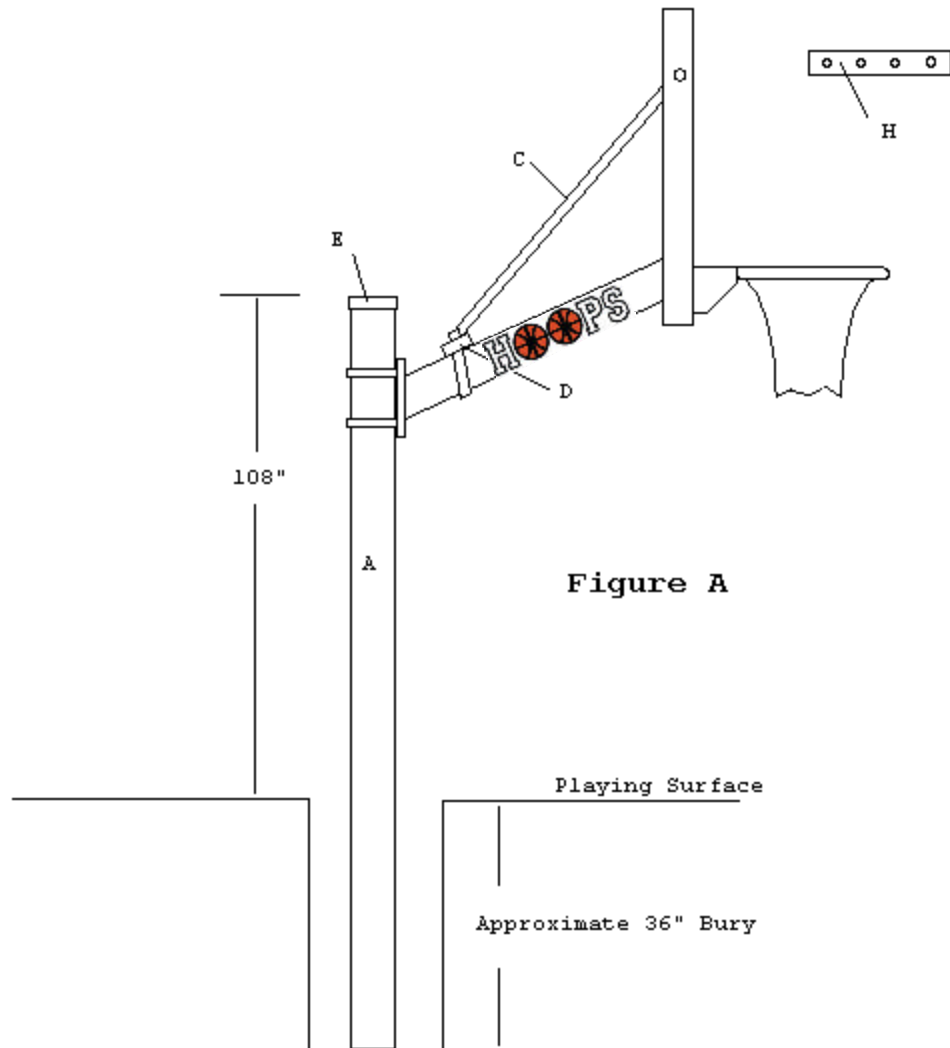

Bill of Materials

- | | |
|-------------------------------|--------------------------------|
| A (1) Vertical Post | J (4) 1/2" Hex Nut |
| B (1) Extension Arm | K (2) 3/8" Flat washer |
| C (2) Backboard Brace | L (2) 3/8" Lock washer |
| D (1) Clamp Bar | M (2) 3/8" Hex Nut |
| E (1) 4" Post Cap | N (2) 5/16" x 1" Machine Screw |
| F (2) 4" U-Bolt | O (2) 5/16" Flat washer |
| G (1) 2" U-Bolt | P (2) 5/16" Lock washer |
| H (1) Backboard Frame Support | Q (2) 5/16" Hex Nut |
| I (4) 1/2" Lock washer | |

Hoops Pro Dunk® Original Select & Premium Assembly Instructions

NOTE: Immediately unpack all components and cross check against bill of materials. Report any shortages to Hoops customer service at 1-866-944-6677.

Instructions

1. Locate and dig a 12" minimum diameter x 36" deep hole.
2. Fill hole with wet premixed concrete, insert vertical pole leaving 108" above desired playing surface. Vibrate to settle concrete. Place 4" square post cap on top of pole.
3. Make sure post is straight and plumb. Brace while drying if necessary. Allow 24 hours minimum drying time before continuing assembly.
4. Using 4"x ½" U-Bolts, lock washers and nuts attach the extension arm to the vertical pole either at the desired rim height or at ground level.
5. Loosely attach backboard braces to extension arm using 2"x 3/8" U-Bolt, clampbar, flat washers, lock washers and nuts.
6. Remove and discard the shipping block (plastic piece) located at the backboard joint. Bolt on backboard frame support to the center four holes located at the top of your backboard using the 5/16" hardware provided with the backboard.
7. Attach desired backboard and rim placing bolts through rim, backboard and extension arm. Tighten with rim level to backboard and arm. Packaged in with your backboard are two black rubber gaskets. Be sure to place one rubber gasket between the face of the backboard and the rim and the other between the extension arm and the backside of the backboard. Trim gaskets if necessary.
8. Attach backboard braces to side holes in backboard frame using 5/16" hardware provided. Bend braces to fit as necessary.
9. Tighten all bolts.
10. If you attached extension arm at ground level, slide entire assembly to desired rim height and tighten U-Bolts making sure entire project is level and square. When sliding assembly, be careful not to scratch the paint on the vertical pole.

Tip: If you are setting the unit at 10 feet, the bottom of the extension arm will be bolted approximately 95 ½" up the vertical post.